

**\*\* NOTE \*\***  
 OVERALL HEIGHT  
 12R TIRE = CURRENT  
 315 TIRE ADD 1 1/4"  
 425 TIRE ADD 2"

----- CHASSIS -----	
CHASSIS:	100"W KME PREDATOR PANTHER
CAB:	LFD WITH 10" RAISED ROOF
ENGINE:	CUMMINS ISL9 450 HP
TRANSMISSION:	ALLISON 3000EVS
FRONT AXLE:	20,000 LBS
REAR AXLE:	27,000 LBS

----- PUMP -----	
PUMP:	HALE QMAX-150 1500 SINGLE STAGE
INTAKES	
DRIVER SIDE:	6" & 2-1/2"
OFFICER SIDE:	6"
FRONT:	6"
REAR:	N/A
DISCHARGES	
DRIVER SIDE:	(1) 3" & (1) 2-1/2"
OFFICER SIDE:	(1) 4" & (1) 2-1/2"
FRONT:	(1) 1 1/2"
REAR:	
DECK GUN:	(1) 3"
OTHER:	(2) 1 3/4" CROSSLAYS (1) BOOSTER REEL (2) 2 1/2" & (1) 1 1/2" FRONT HOSE BED

----- TANK -----	
TANK:	POLY
WATER:	1,000 GALLONS
FOAM:	30 GALLONS
EXTRA FILLS:	(2) 2 1/2" AKRONS AT REAR
DUMPS:	N/A

----- BODY -----	
BODY TYPE:	158" FLEX MEDIUM
MATERIAL:	3/16" ALUMINUM
COMPARTMENTATION	
DRIVER SIDE:	FULL HEIGHT/SPLIT DEPTH
OFFICER SIDE:	LOW SIDE
HOSEBED	
DIVIDERS:	FOUR (4)
HOSE LOAD:	CUSTOMER SPECIFIED

----- MISC. -----	
GENERATOR:	ONAN 6,000 PTO/HYD IN HOSE BED
FOAM SYSTEM:	AKRON 3126-125 GPM EDUCTOR

**CUSTOMER APPROVAL:**

NAME: \_\_\_\_\_

TITLE: \_\_\_\_\_

DATE: \_\_\_\_\_

THIS DRAWING IS A GENERAL CONFIGURATION AND MAY NOT NECESSARILY REFLECT ALL CONTRACTUAL REQUIREMENTS. CONTRACT SPECIFICATIONS SHALL PREVAIL OVER DRAWING

REV	DATE	DESCRIPTION	APP'D
B	3-26-13	REVISED PROPOSAL	
A		PROPOSAL	MH
SYM	DATE	REVISION DESCRIPTION	APP'D

SALES ENGINEER : MIKE MESSNER

  
**KOVATCH MOBILE EQUIPMENT**  
 ONE INDUSTRIAL COMPLEX - NESQUEHONING, PA 18240  
 DIMENSIONS ARE APPROXIMATE & MAY VARY DUE TO BUILD ADJUSTMENTS  
 DATE: 02/28/2013 SCALE: 1"=24" DVG SIZE: D DRAWN BY: JJM APPROVED BY: \_\_\_\_\_

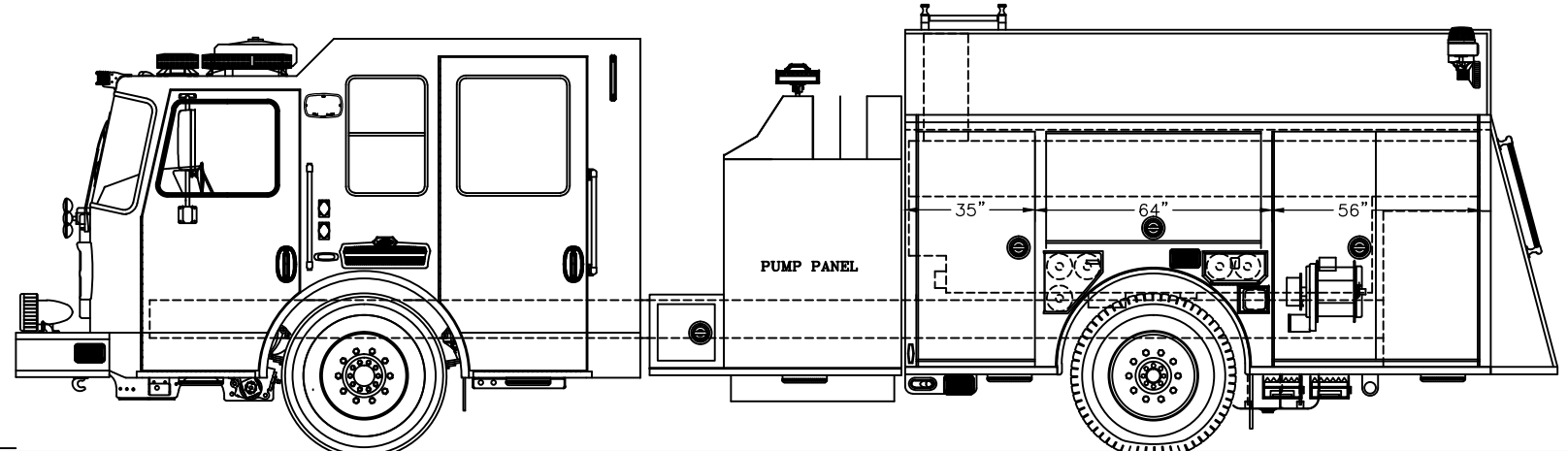
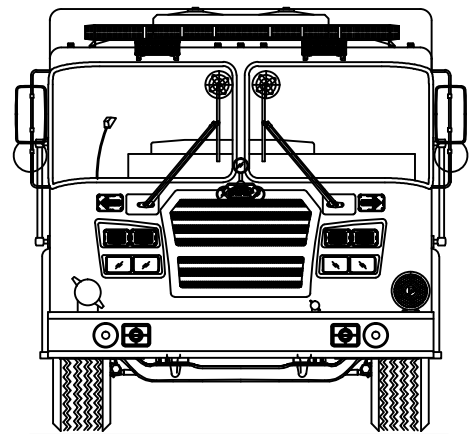
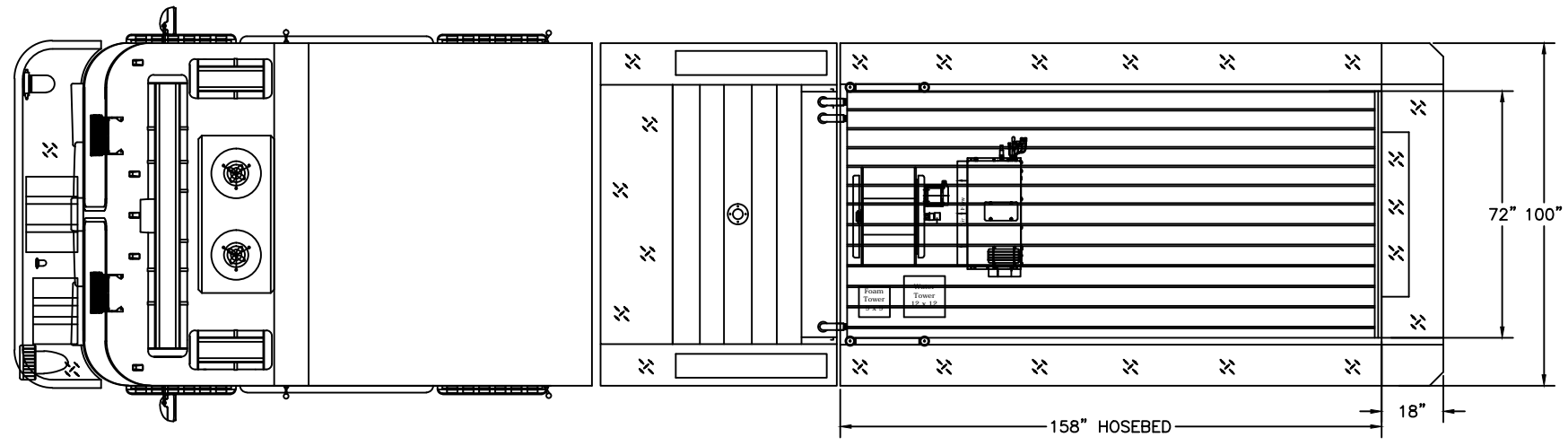
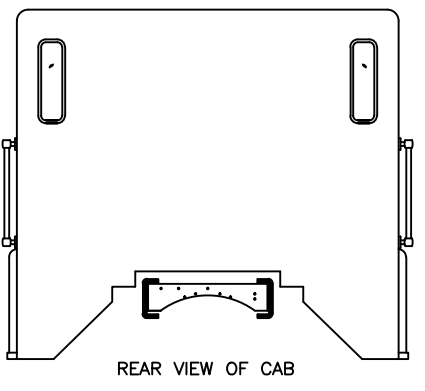

2 1/2"      1"