

**SPECIFICATIONS**

CHASSIS: GMC TC 5500 4X2 4DR  
 ENGINE: 300 HP  
 TRANSMISSION:  
 FRONT AXLE: 8,000#  
 REAR AXLE: 19,000#  
 PUMP: HAILE AP-50, 500 GPM PTO PUMP  
 WATER TANK: 400 GALLON UPF POLY IIR

**COMPARTMENT SIZE**

(A/D): 62"H X 31 3/4"W X 26"D  
 (B/E): 62"H X 36 3/4"W X 28"D  
 (C/F): 34"H X 44 1/2"W X 28"D  
 (G): 26"H X 42"W X 24"D

**DOOR OPENING**

(A/D): 61"H X 28"W  
 (B/E): 61"H X 36"W  
 (C/F): 31 1/2"H X 40"W  
 (G): 24"H X 37 1/2"W

**DISCHARGES**

(1) 2 1/2" LEFT SIDE  
 (2) 2 1/2" RIGHT SIDE  
 (2) 1 3/4" CROSSTAYS

**SUCTIONS**

(1) 2 1/2" AUX. LEFT SIDE (2) 5" MAIN, 1 EACH SIDE

**PLEASE REVIEW AND RETURN  
 A SIGNED COPY.**

NAME: \_\_\_\_\_  
 TITLE: \_\_\_\_\_  
 DATE: \_\_\_\_\_

**CUSTOMER PAINT CODES:**

LOWER CAB AND BODY: \_\_\_\_\_  
 CAB TWO TONE: \_\_\_\_\_

THIS DRAWING IS A GENERAL CONFIGURATION AND MAY NOT  
 NECESSARILY REFLECT ALL CONTRACTUAL REQUIREMENTS.

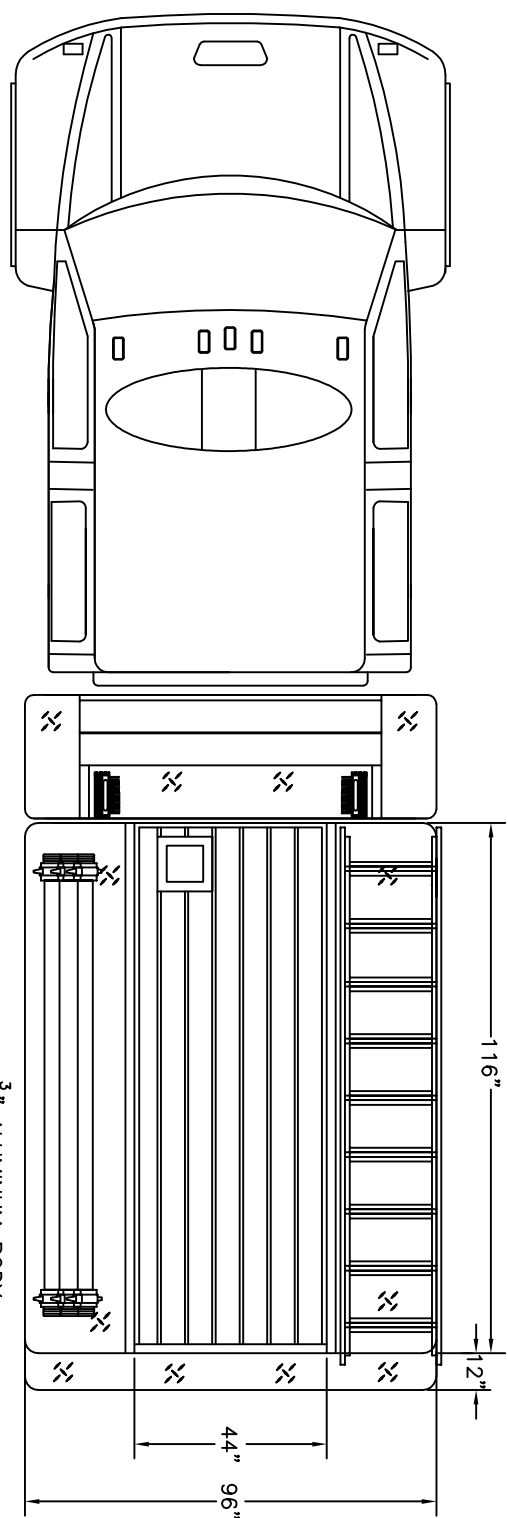

3/8" ALUMINUM BODY

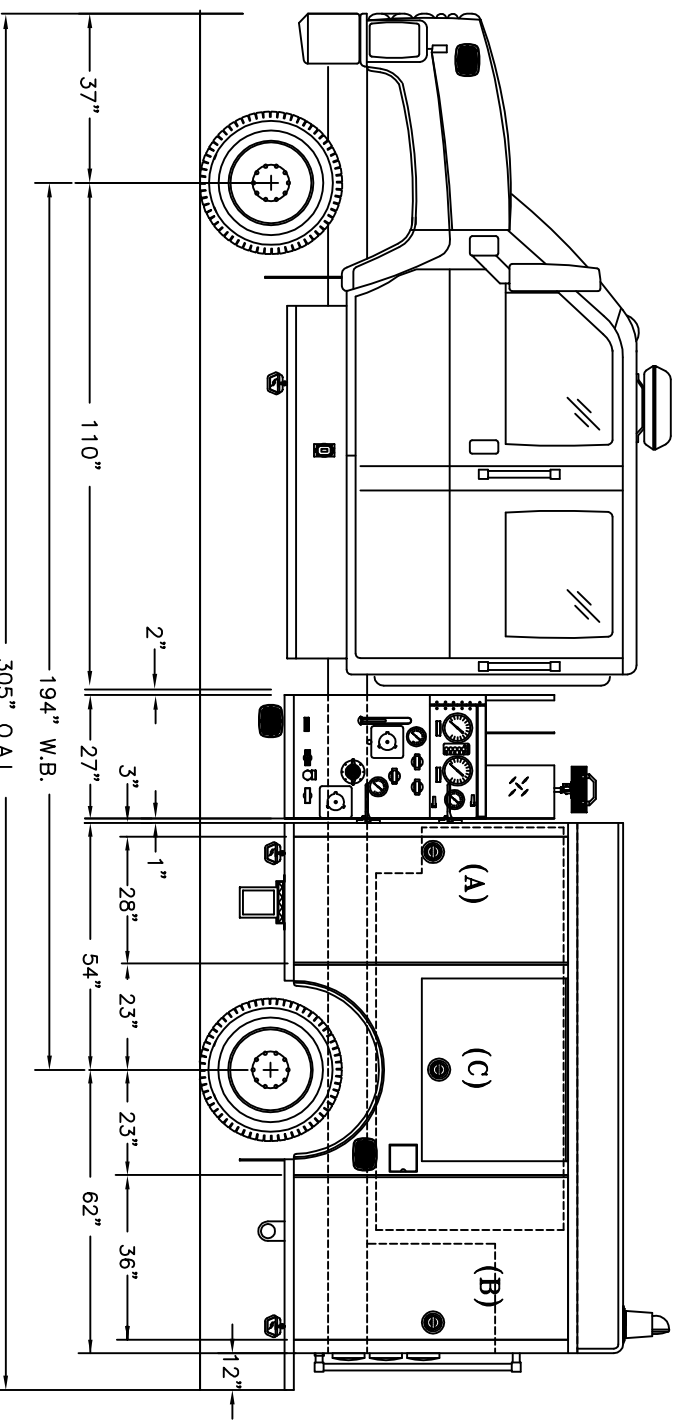
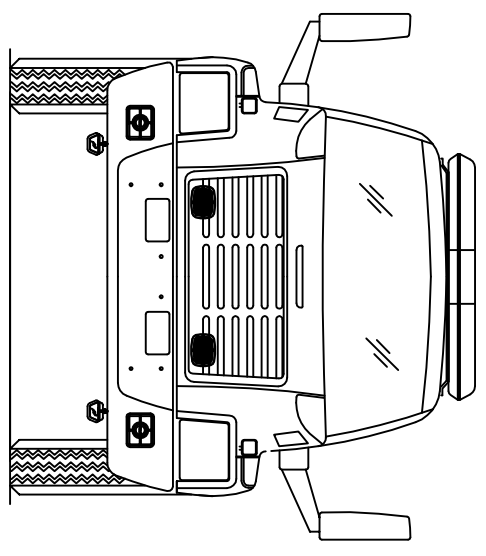

SV#	DATE	REVISION DESCRIPTION	APP'D
A		PROPOSAL	B.A.C.

SALES ENGINEER : BRIAN CONNELLY

**KOVATCH MOBILE EQUIPMENT**  
 ONE INDUSTRIAL COMPLEX  
 RESQUOINING, PA 18240

TOLERANCE UNLESS OTHERWISE SPECIFIED  
 DECIMALS THREE PLACE: ±.030 ANGLES: ±.2°  
 FRACTIONS: ±1/8"  
 ONE PLACE: ±.080 THREE PLACE: ±.010 REMOVE ALL SHARP  
 TWO PLACE: ±.030 AND SHARP EDGES

DATE: 5-17-08 SCALE: NONE DRAWN BY: JIM APPROVED BY: B.C.

**KME MINI PUMPER**

FAIR HAVEN NY

GSO#6238

**CAD**

DO NOT CHANGE MANUALLY