

OFFICERS SIDE VIEW

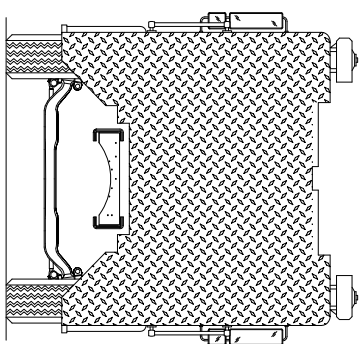

REAR VIEW OF CAB

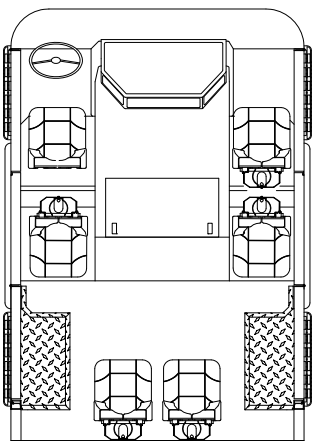

CAB INTERIOR LAYOUT

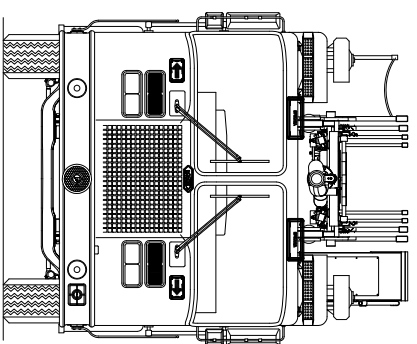

FRONT VIEW

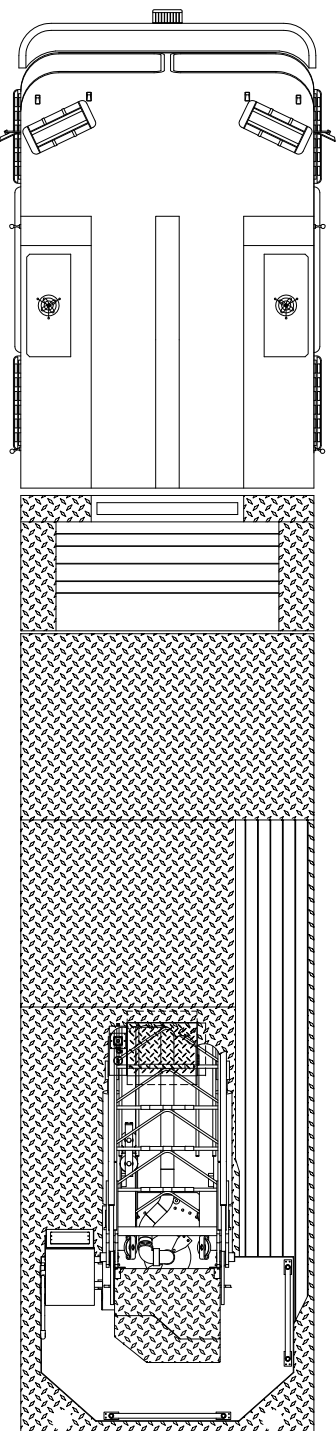

TOP VIEW

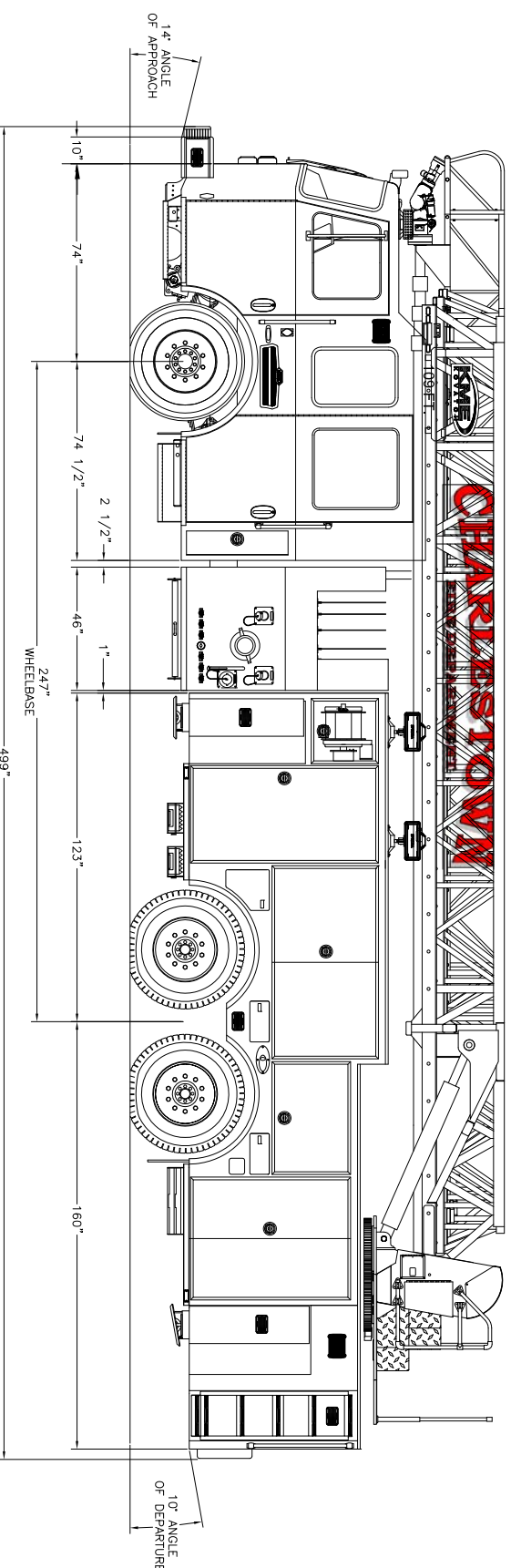

DRIVERS SIDE VIEW

SPECIFICATIONS

CHASSIS: PREDATOR LTD w/ 10" RAISED ROOF
 ENGINE: CUMMINS ISX 12 500 HP w/ ENGINE BRAKE (2010 EPA)
 TRANSMISSION: ALLISON 4000EVS 5-SPEED AUTOMATIC
 FRONT AXLE: MERITOR MFS-20-133A-N; #23,000
 REAR AXLE: MERITOR RT-58-185; #58,000
 PUMP: HALE Q-MAX, 2000 GPM, SINGLE STAGE
 TANK: 650 GALLON POLY/VE

COMPARTMENT SIZE			
COMPT.	DOOR OPENING HEIGHT	COMPARTMENT HEIGHT	INTERIOR DEPTH
L1	23-1/4"	22-3/8"	27-1/2"
L2	88-5/8"	34-5/8"	34-5/8"
L3	37-7/8"	80"	41-1/2"
L4	26"	23-5/8"	31-1/2"
L5	58-3/8"	44"	62-1/8"
R1	23-1/4"	22-3/8"	27-1/2"
R2	68-5/8"	34-5/8"	72-1/8"
R3	27"	44"	32"
B1	41"	10-1/2"	43"

GROUND LADDERS

- 1 - ALCO-LITE 35' 2-SECTION: PEL-35
- 1 - ALCO-LITE 28' 2-SECTION: PEL-28
- 1 - ALCO-LITE 24' 2-SECTION: PEL-24
- 1 - ALCO-LITE 18' ROOF w/ FOLDING HOOKS: PRL-18 (MOUNTED ON AERIAL DEVICE)
- 2 - ALCO-LITE 16' ROOF w/ FOLDING HOOKS: PRL-16
- 1 - ALCO-LITE 14' ATTC EXTENSION: AEL-14
- 1 - ALCO-LITE 10' FOLDING: FL-10

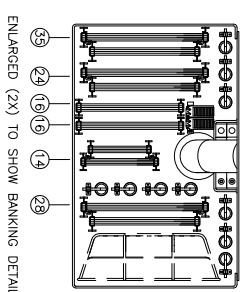

ENLARGED (2X) TO SHOW BANKING DETAIL

DISCHARGES

- (2) 2 1/2" DRIVERS SIDE
- (1) 2 1/2" & (1) 4" OFFICERS SIDE
- (2) 1 3/4" CROSSLAY
- (1) 2 1/2" CROSSLAY
- (1) 3" AERIAL WATERWAY

THIS DRAWING IS A GENERAL CONFIGURATION AND MAY NOT NECESSARILY REFLECT ALL CONTRACTUAL OBLIGATIONS. DIMENSIONS ARE APPROXIMATE AND MAY VARY DURING CONSTRUCTION. PLEASE REVIEW AND RETURN A SIGNED COPY.

NAME: _____
 TITLE: _____
 DATE: _____

CUSTOMER PAINT CODES

LOWER CAB AND BODY: RED PPG# 71660
 CAB TWO TONE: WHITE PPG# 2185
 LADDER: WHITE PPG #2185
 COMPARTMENT INTERIOR: JOB COLOR w/ SPLATTER PAINT

B 1-24-14 CHANGES PER SIGNED PRE-CON LETTER
 REV DATE REVISION DESCRIPTION APP'D

SALES ENGINEER : MARK BOYLE



KME KOVATCH
 KME FIRE APPARATUS
 ONE INDUSTRIAL COMPLEX
 NESQUEHONING, PA 18240

DATE: 6-28-13 SCALE: NONE DRAWN BY: ZCZ
 APPROVED BY: FPH

109' AERIAL CAT REAR MOUNT LADDER

CHARLESTOWN, MD

CSO #9347

DO NOT CHANGE MANUALLY