

NOTE:
 120 THE 400 1 1/2"
 315 THE 400 1 1/4"
 425 THE 400 2"

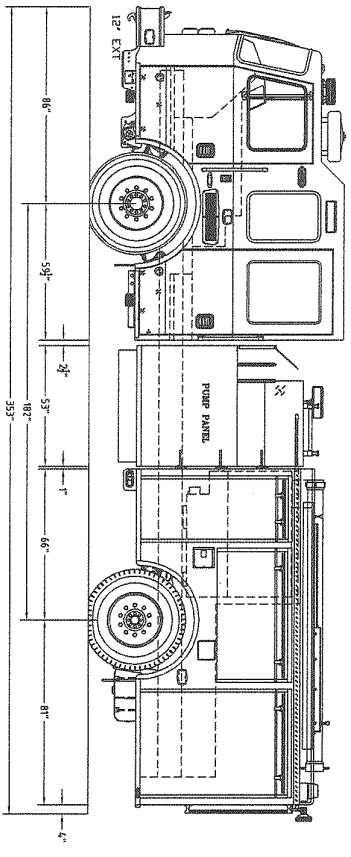
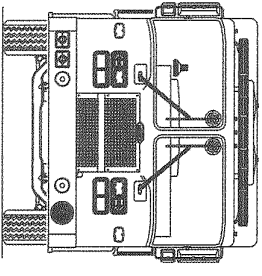
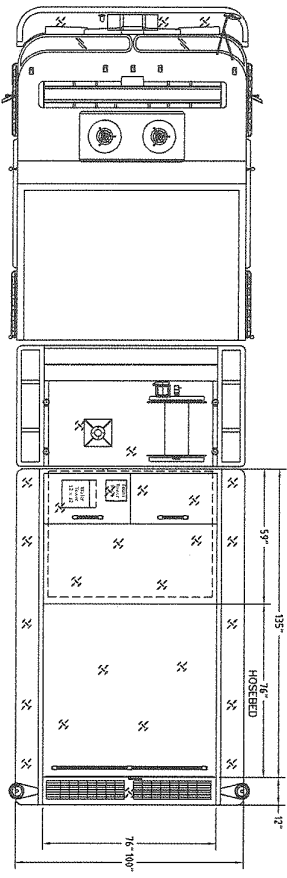
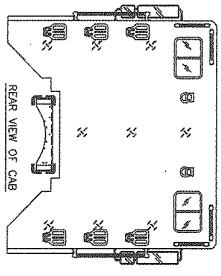

CHASSIS

1047# KME PREPARED 355" X100"
 CUMMINS 4 CYLINDER ISX12 450 HP
 TRANSMISSION: ALISON 46005VS
 REAR AXLE: 27000 LB

PUMP

PUMP: HALT Q2-150 1500 TWO STAGES
 INLET: 3" & 2-1/2"
 DRIVER SIDE: 3" & 2-1/2"
 OFFICER SIDE: 3" & 2-1/2"
 FRONT: N/A
 REAR: N/A
 DRIVER SIDE: (3) 3-1/2" (2) 2-1/2"
 OFFICER SIDE: (1) 3" (2) 2-1/2"
 REAR: (1) 2 1/2" BS
 DRCK OUN: (1) 4" 3/4" CROSSAINS
 OTHER: (1) BOSTER REEL

TANK

TANK: POLY
 FOLK: 90 GALLONS
 EXTRA FILLS: N/A
 BUBBLES: N/A

BODY

BODY TYPE: 194" FLAT BACK
 COMPARTMENT: 1' of CUMMINS
 DRIVER SIDE: PULP HEIGHT/SPLIT DEPTH
 OFFICER SIDE: PULP HEIGHT/SPLIT DEPTH
 BUBBLER: THREE (3)
 HOSE LOAD: 400' OF 3-1/2"
 400' OF 3"
 150' OF 1 3/4"

MISC.

GENERATOR: N/A
 FOLW SYSTEM: ELKADER #840-155P CPW FOLW EDUCOR

CUSTOMER APPROVAL:

NAME: _____
 TITLE: _____
 DATE: _____

C	12-12-12	REVISED	RS
B	11-29-12	REVISED	RS
A	10-31-12	REVISED	RS
SYM	DATE	REVISION DESCRIPTION	APP'D
SALES ENGINEER: RYAN SLANE			

KME
 KOVATOH

KOVATOH MOBILE EQUIPMENT
 1000 W. WILSON ST. SUITE 100
 ATLANTA, GA 30310
 PHONE: 404.525.1100
 FAX: 404.525.1101
 WWW.KME.COM

THIS DRAWING IS A GENERAL CONFORMANCE AND MAY NOT
 NECESSARILY REFLECT ALL CONTRACTUAL REQUIREMENTS
 CONTRACT SPECIFICATIONS SHALL PREVAIL OVER DRAWING

10/10/2012 1:54 PM
 SCALE: DWG STRIPPED BY J.J.M.
 APPROVED BY RS

KME CUSTOM PUMPER
 ATLANTA, GA
 GSO#8793 THRU 8796