

SPECIFICATIONS

CHASSIS: PREDATOR LTD w/ 6" RAISED ROOF
 ENGINE: CUMMINS ISM 500 HP w/ ENGINE BRAKE
 TRANSMISSION: ALLISON 400EERS 5-SPEED AUTOMATIC
 FRONT AXLE: MERITOR #5-205360N #253000
 REAR AXLE: MERITOR #5-205360N #253000
 PUMP: HALE O-MAX-200 2000 GPM SINGLE STAGE
 TANK: 300 GALLON POLYME

COMPARTMENT SIZE

Letter Designation	Floor Opening (width)	Internal Compartment Size (width) Depth	Height
(L1)	50-1/2 x 20	54	24
(L2)	29-1/2 x 25-3/8	53	20-9/8 x 14
(L3)	29-1/2 x 28	70-1/2 / 28-1/2	32
(L4)	29-1/2 x 27-3/4	33	27-3/8 x 27
(L5)	29-1/2 x 27-3/4	28	31-3/4 x 14
(L6)	60	27	63-1/2 / 18
(L7)	29-1/2 x 25	20	20
(L8)	60	20	63-1/2 / 18
(L9)	29-1/2 x 20	54	24
(R1)	29-1/2 x 25-3/8	54	20-9/8 x 10
(R2)	29-1/2 x 43-3/8	30	70-1/2
(R3)	29-1/2 x 53-7/8	26	27-3/8 x 27
(R4)	24	53-7/8	57-7/8 x 14 / 11
(R5)	24	53-7/8	57-7/8 x 14 / 11
(R7)	31	27	34-1/2 / 18
(R8)	31	20	34-1/2 / 18
(R9)	31	20	34-1/2 / 18
(B)	24-1/2 x 22-3/4	25	24-3/4 x 21-1/2

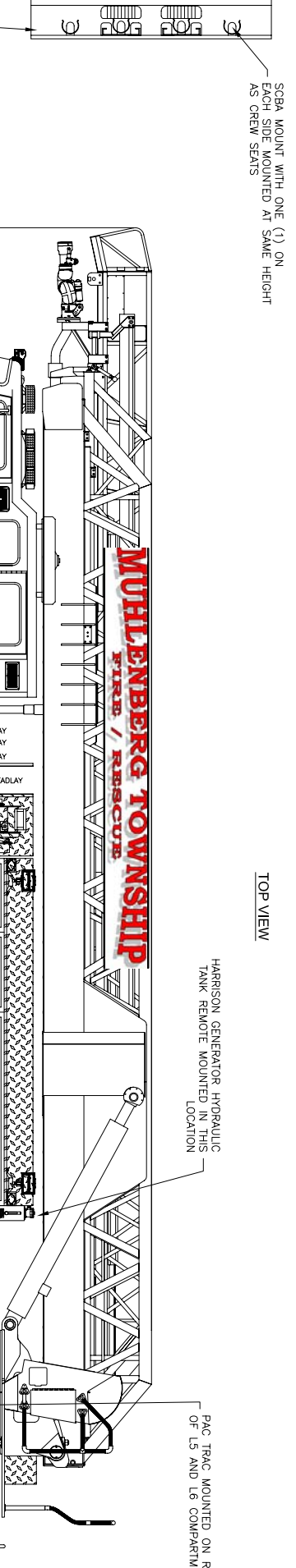
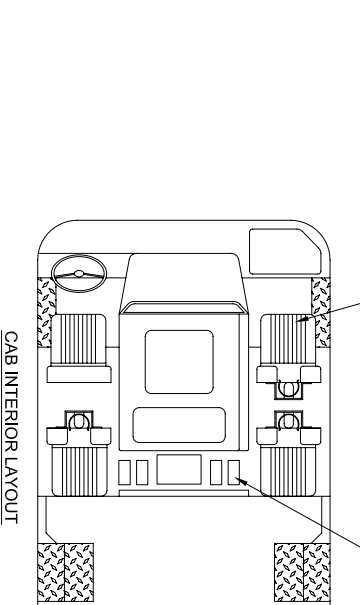
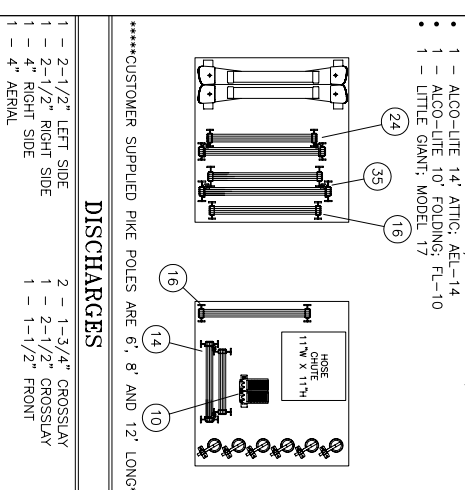
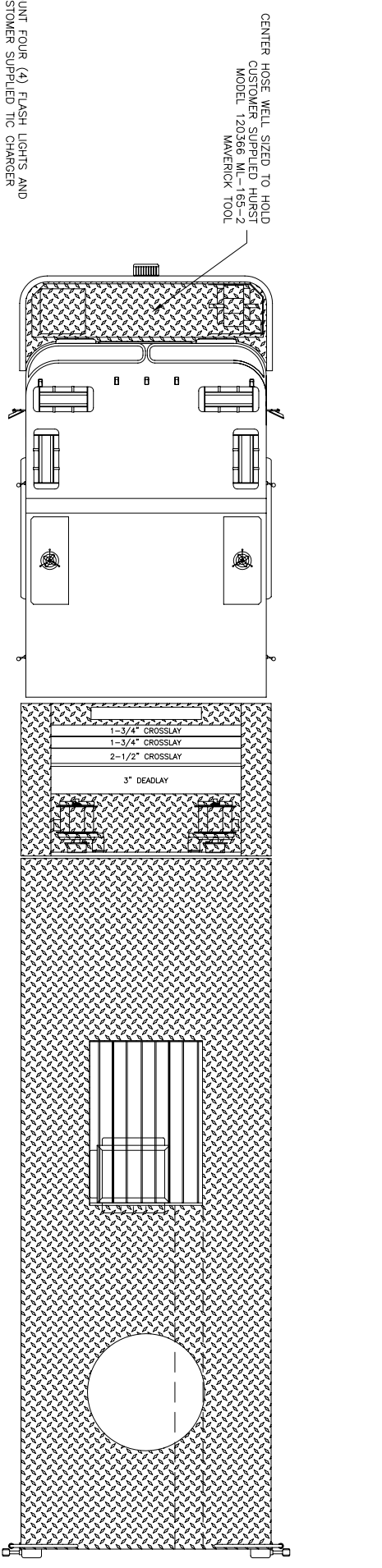
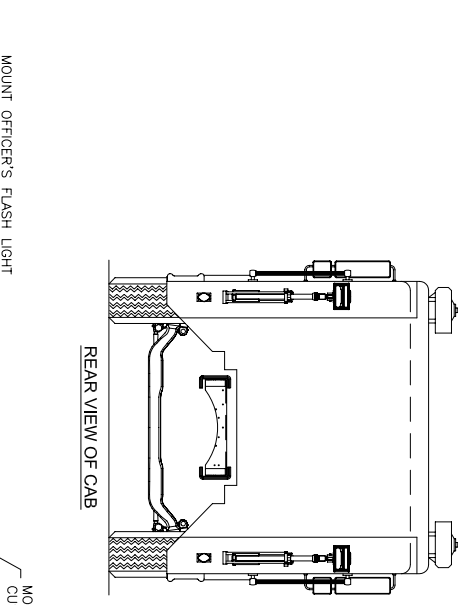

CUSTOMER PAINT CODES

LOWER CAB AND BODY: PG RED #71528
 CAB TWO TONER: PPG WHITE #2185
 LADDER: PPG WHITE #2185
 COMPARTMENT INTERIOR: ZOLATONE MARBLE WHITE

SALES ENGINEER : JASON BEHLER

REV	DATE	DESCRIPTION	APP'D
A	17NOV09	PRE CONSTRUCTION MEETING	JUB
REV	DATE	REVISION DESCRIPTION	APP'D

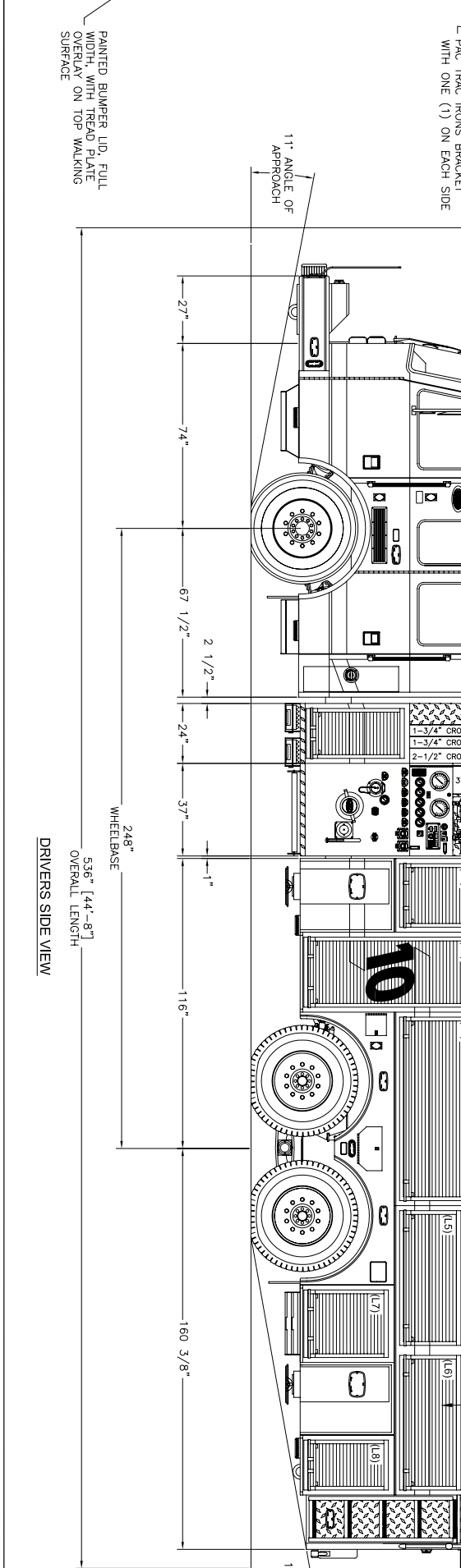
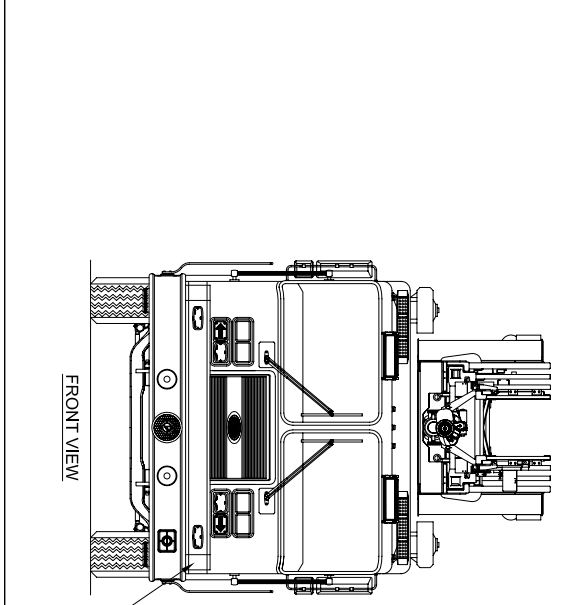

KME FIRE APPARATUS

ONE INDUSTRIAL COMPLEX
 NESQUEHONING, PA 16240

DATE: 13JUL09 SCALE: NONE DRAWN BY: S. HEISER APPROVED BY: PPH

THIS DRAWING IS THE PROPERTY OF KME FIRE APPARATUS. IT IS TO BE USED FOR THE PURPOSE SPECIFICALLY INTENDED. IT IS NOT TO BE REPRODUCED OR TRANSMITTED IN ANY FORM OR BY ANY MEANS, ELECTRONIC OR MECHANICAL, INCLUDING PHOTOCOPYING, RECORDING, OR BY ANY INFORMATION STORAGE AND RETRIEVAL SYSTEM.

GOODWILL FIRE COMPANY, PA

GSO 7842

DO NOT CHANGE MANUALLY