

----- CHASSIS -----

CHASSIS: KME PREDATOR XMPD 12" RR
 CAB: 4 DOOR
 ENGINE: CAT C13 430 HP
 TRANSMISSION: ALLISON 4000 EVS
 FRONT AXLE: 20,000#
 REAR AXLE: 27,000#

----- PUMP -----

PUMP: HALE QMAX-150 1500 GPM SINGLE STAGE

INTAKES
 DRIVER SIDE: 6"
 OFFICER SIDE: 6" & 2-1/2"
 FRONT: 6"
 REAR: 6"

DISCHARGES
 DRIVER SIDE: N/A
 OFFICER SIDE: (1) 2 1/2" & (1) 3"
 FRONT: (1) 1 1/2"
 REAR: (2) 2 1/2" FRONT HOSE BRD
 DECK GUN: (3) 3 3/4" CROSSLAWS
 OTHER: (1) 2 1/2" CROSSLAW

----- TANK -----

TANK: FIBERGLASS
 WATER: 1,000
 FOAM: 20
 EXTRA FILLS:
 DUMPS:

----- BODY -----

BODY TYPE: CHALLENGER WB
 MATERIAL: 3/16" ALUM
 COMPARTMENTATION
 DRIVER SIDE: FULL HEIGHT-FULL DEPTH
 OFFICER SIDE: FULL HEIGHT-SPLIT DEPTH
 HOSEBED
 CAPACITY: 141 CUBIC FEET
 DIVIDERS: THREE (3)
 HOSE LOAD: 1000' - 5"
 1000' - 3"

----- MISC. -----

GENERATOR: HARRISON PTO/HYD 15 MPC
 FOAM SYSTEM: HALE FOAMLOGIX 2.1/EZ-FILL REFILL SYS

CUSTOMER APPROVAL:

NAME:
 TITLE:
 DATE:

THIS DRAWING IS A GENERAL CONFIGURATION AND MAY NOT
 NECESSARILY REFLECT ALL CONTRACTUAL REQUIREMENTS.
 CONTRACT SPECIFICATIONS SHALL PREVAIL OVER DRAWING

SYM	DATE	REVISION DESCRIPTION	APP'D

SALES ENGINEER : JASON WITAJER



KOVATCH MOBILE EQUIPMENT
 ONE INDUSTRIAL COMPLEX - NISSAUBOROUGH, PA 18820

DIMENSIONS ARE APPROXIMATE & MAY VARY DUE TO BUILD ADJUSTMENTS
 DATE SCALE DWG SIZE/DRAWN BY APPROVED BY
 10-12-07 1"=24" D JGW JGW
KME CUSTOM PUMPER

STOCK
 GSO#7095

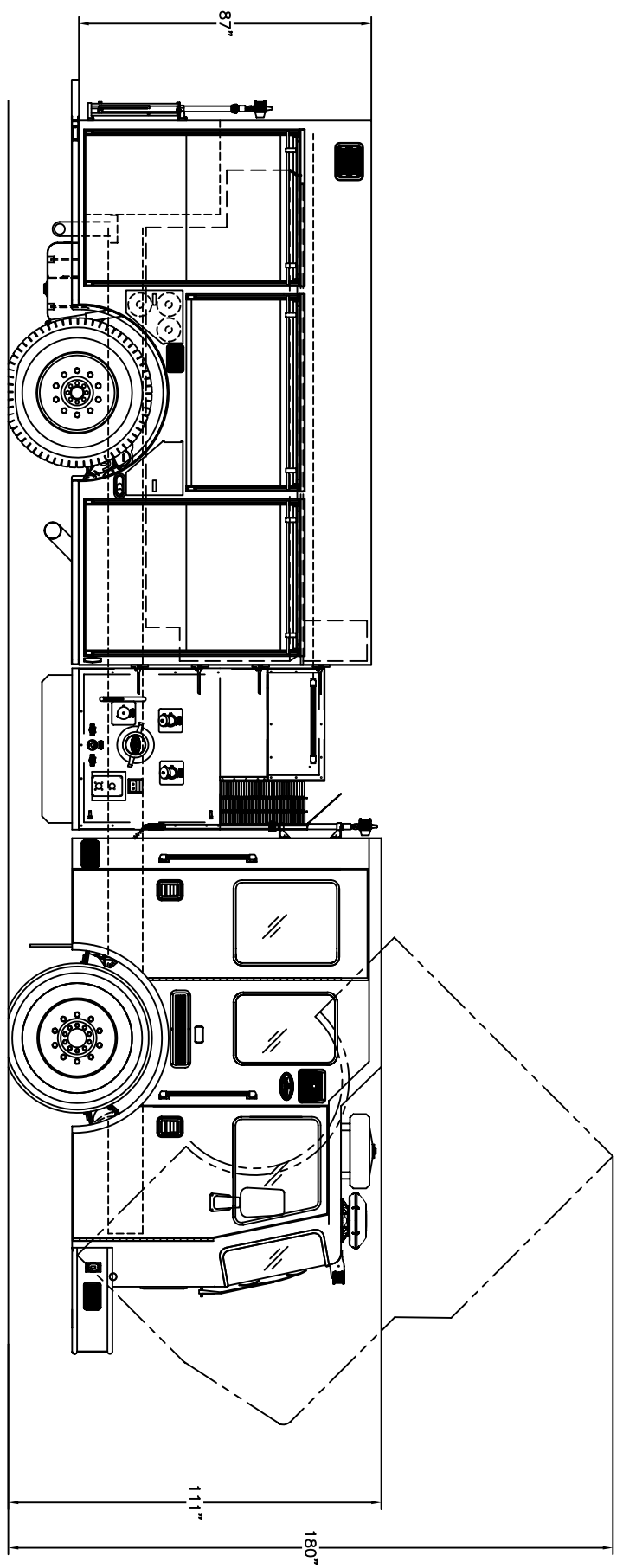

(2) 200' FRAGMENTS 1000' - 5' SAFETY HOSE
 1000' - 3' DEAD LOAD 2-1/2" OR 3" HOSE

