

REAR VIEW OF CAB

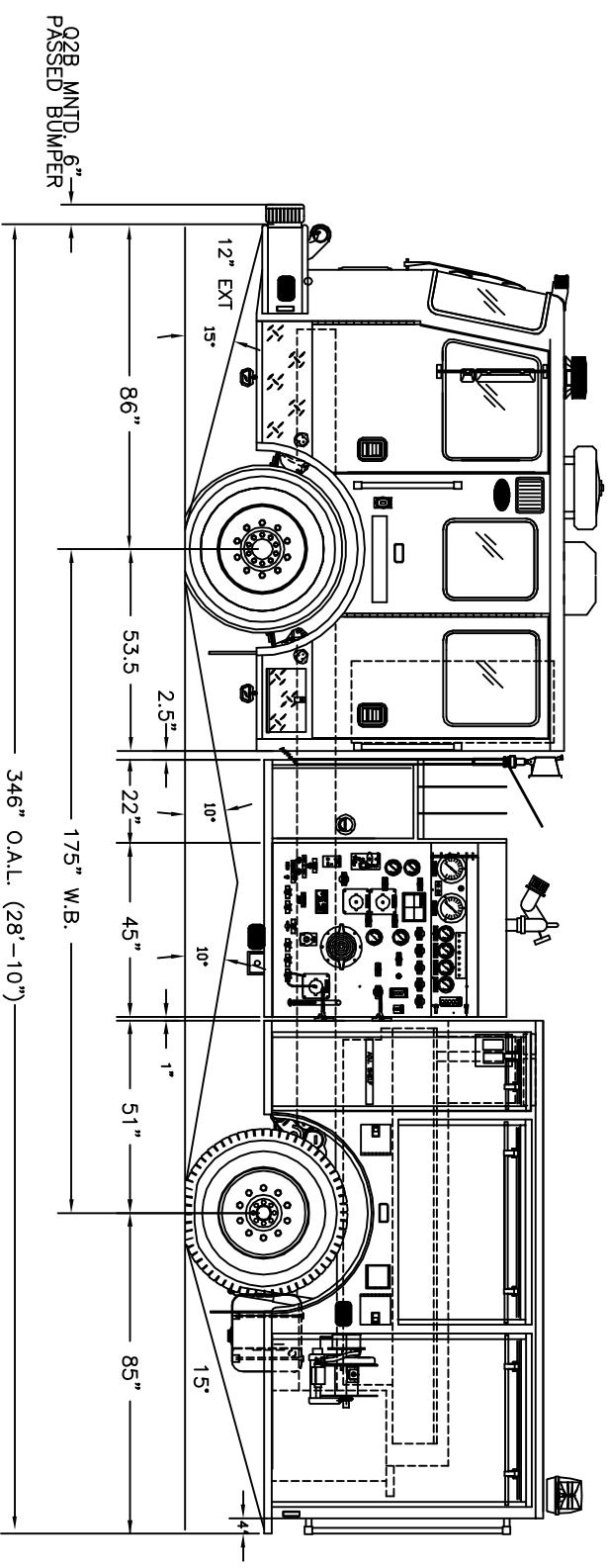
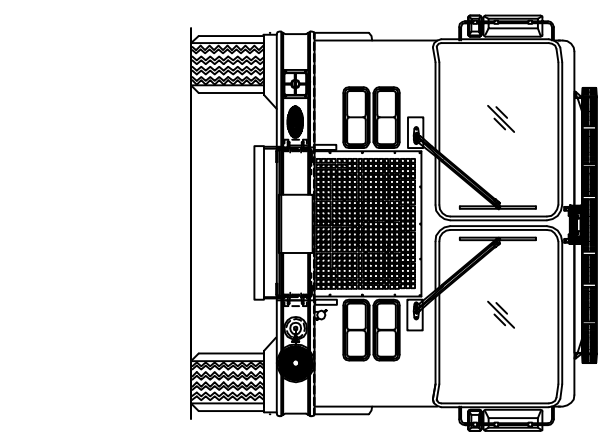
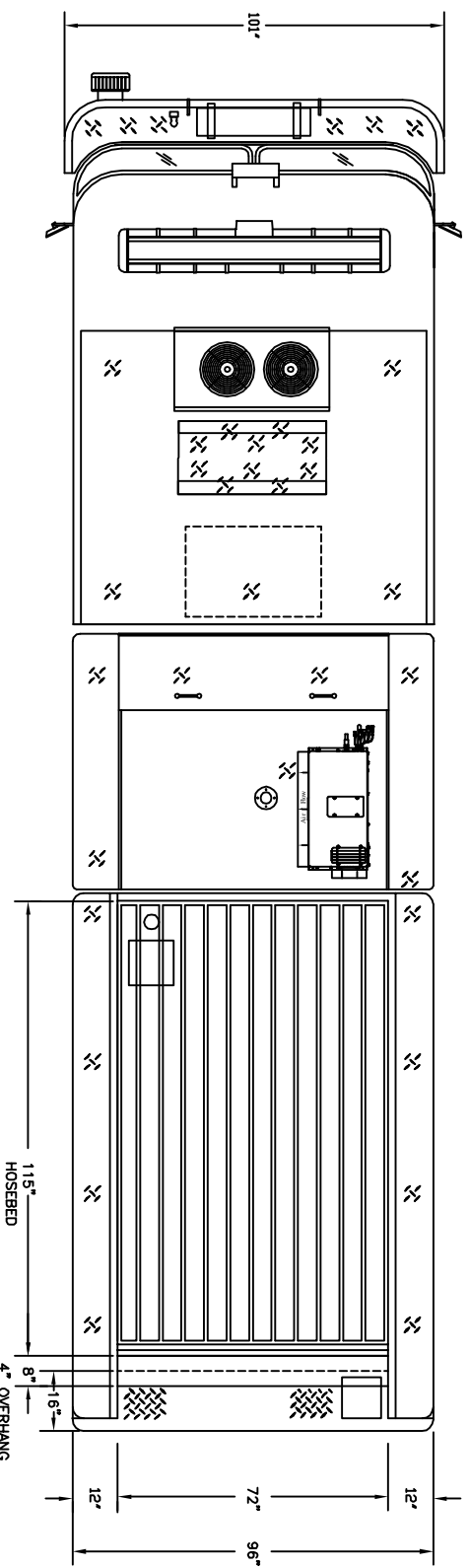

----- CHASSIS -----

CHASSIS: KME PREDATOR "SS" MPD FLAT ROOF
 CAB: 4 DOOR DIESEL 425 HP W/JAKE
 ENGINE: DETROIT DIESEL 4000EVS
 TRANSMISSION: ALLISON 4000EVS
 FRONT AXLE: 18,740#
 REAR AXLE: 24,000#

----- PUMP -----

PUMP: WATEROUS CSU-C10-2000 GPM

INTAKES: DRIVER SIDE: 6" & 2 1/2"

OFFICER SIDE: 6"

FRONT: REAR:

DISCHARGES: DRIVER SIDE: (2) 2 1/2" & (1) 3" x 5" STORZ

OFFICER SIDE: (1) 2 1/2" & (1) 3" x 5" STORZ

FRONT: (1) 1 1/2" + (1) 3" RH & (1) 1-1/2"

REAR: (1) 3" W/ EXHAUST 8297-51

DECK GUN: (1) 3" W/ EXHAUST 8297-51

OTHER: (2) 1 3/4" CROSSLAYS

----- TANK -----

TANK: UPF POLY IIR

WATER: 500

FOAM: 25

EXTRA FILLS: DUMPS:

----- BODY -----

BODY TYPE: 132" FLATBACK

MATERIAL: 3/16" ALUMINUM

COMPARTMENTATION: DRIVER SIDE: 70" HIGH FULL HEIGHT-SPILT DEPTH

OFFICER SIDE: LOW

HOSEBED: CAPACITY: 70 CU. FT.

DIVIDERS: FOUR (4)

HOSE LOAD: 150' OF 2-1/2"

500' OF 3"

150' OF 3"

----- MISC. -----

GENERATOR: HARRISON 8,000 WATT MOBILE HYD

FOAM SYSTEM: FOAM PRO 2002

CUSTOMER APPROVAL:

NAME: _____

TITLE: _____

DATE: _____

THIS DRAWING IS A GENERAL CONFIGURATION AND MAY NOT NECESSARILY REFLECT ALL CONTRACTUAL REQUIREMENTS. CONTRACT SPECIFICATIONS SHALL PREVAIL OVER DRAWING.

SY#	DATE	REVISION DESCRIPTION	APP'D.
B	02/02/07	REVISED PER PRE-BUILD MEETING	MAK
A	01/15/07	PROPOSAL TO CONTRACT	MAK
SYM			APP'D.

SALES ENGINEER : MARK KOPUNEK



KOVATCH MOBILE EQUIPMENT
 ONE INDUSTRIAL COMPLEX - HERSHEY, PA 17033

DIMENSIONS ARE APPROXIMATE & MAY VARY DUE TO BUILD ADJUSTMENTS

DATE: 1-2-07 SCALE: 1"=24" DWG SIZE: D

APPROVED BY: J.J.M. MAK

KME CUSTOM PUMPER

CITY OF PITTSBURGH, PA

GSO#6845, 6846 & 6847